

## Energy bars individually wrapped and loaded into cartons

330 bars/minute collated “lying flat” or “on edge”  
in groups of 4, 6, 7, 8 and 9 per carton



This contract manufacturer for the energy bar market came to Langen Group with a desire to run many different bar sizes and carton load configurations. They wanted to ensure that the equipment they purchased was adaptable, easy to change over and repeatable on product set-ups.

Langen Group proudly offered our C-1000i cartoning solution. The simple functionality of the 1 wrapper/1 cartoner solution appealed to the customer and the easy change over between on-edge bar orientation and flat bar orientation in the cartoner made their decision easy.

Langen Group was able to offer the 3— C-1000i cartoners for the same capital expenditure as a single cartoner solution without the higher complexity and reduced adaptability.

We are focused on application excellence in every project. The built in redundancy that our customers seek with multiple flow wrappers is only naturally extended to the cartoners. Higher OEE and flexibility are the key drivers for the success of the C-1000i.

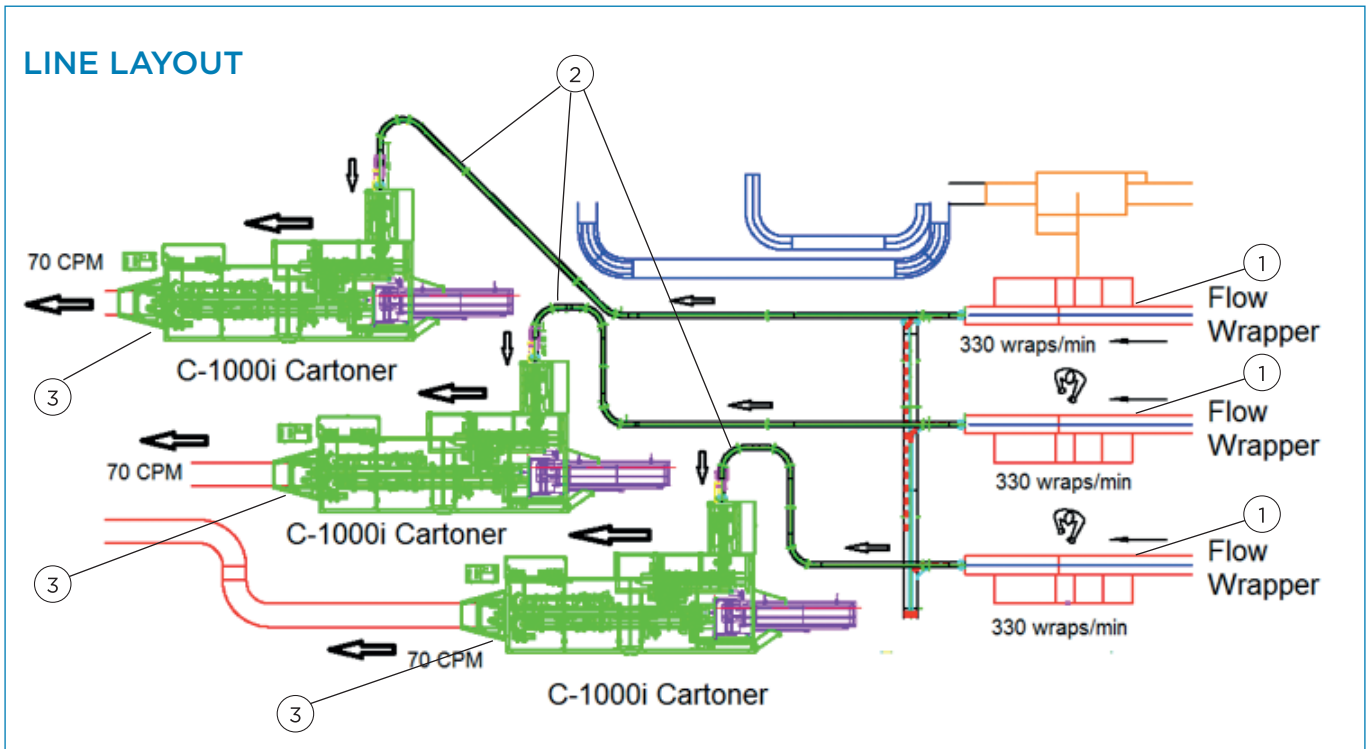

1. Flow wrappers    2. Conveyors    3. Langen Group C-1000i

### Requirements summarized

- Wrap dimensions:
  - 121 mm x 28 mm x 19 mm / 4.75" x 1.12" x 0.75"
  - 84 mm x 19 mm x 13 mm / 3.31" x 0.75" x 0.50"
  - 83 mm x 38 mm x 16 mm / 3.25" x 1.50" x 0.63"
  - 102 mm x 57 mm x 22 mm / 4.00" x 2.25" x 0.88"
- Product: Energy Bars
- Carton Sizes:
  - 165 mm x 48 mm x 152 mm / 6.50" x 1.88" x 6.00"
  - 133 mm x 48 mm x 157 mm / 5.25" x 1.88" x 6.19"
  - 222 mm x 48 mm x 152 mm / 8.75" x 1.88" x 6.00"
  - 102 mm x 54 mm x 152 mm / 4.00" x 2.13" x 6.00"
  - 152 mm x 57 mm x 121 mm / 6.00" x 2.25" x 4.75"
  - 165 mm x 49 mm x 140 mm / 6.50" x 1.94" x 5.50"
  - 165 mm x 70 mm x 140 mm / 6.50" x 2.75" x 5.50"
- Minimum 4 bars/carton, Maximum 9 bars/carton
- Maximum 330 bars/minute; 70 cartons/minute

### Challenges summarized

- Odd count product is loaded on edge while even count product is lying flat in stacks of 2 or 3 in carton
- Small bars are very narrow and unstable to stack
- Broad range of pack patterns
- Food application with corresponding requirements

### Solution highlights

- LSP with quick change product collation belts allows for 30 minute change over
- Compact cartoner layout allows for tight floorspace installation
- One cartoner per flow wrapper solution allows for simplified line controls and increased operational efficiencies
- High speed, high capacity solution with limited floorspace

All information given in this document is dependent upon final machine specification, infeed arrangement, product type and carton specification.

#### AMERICAS

EUROPE, MIDDLE EAST & AFRICA  
ASIA & AUSTRALIA

Canada  
The Netherlands  
Singapore  
Thailand

Ph: +1 905 670 7200  
Ph: +31 24 648 66 55  
Ph: +65 62 89 37 88  
Ph: +66 23 02 14 15

sales-americas@langengroup.com  
sales-europe@langengroup.com  
sales-asia@langengroup.com  
sales-asia@langengroup.com

