

## Stick packs from 3 multilane stick packers

More than 1100 sticks per minute packed in carton with 24 sticks each



### Requirements summarized

- Stick dimension: 146 mm x 44 mm x 9 mm / 5.75" x 1.73" x 0.35"
- Stick contents: 10 gr / 0.35 Oz. coffee powder
- Maximum 56 cartons per minute
- 24 sticks per carton

### Challenges summarized

- Seamless integration with different stick pack machines (8 - 12 lanes)
- Sampling function
- Promotional add on function
- Food application with corresponding requirements

## MACHINE LAYOUT BOMB-BAY SYSTEMS FOR STICKS

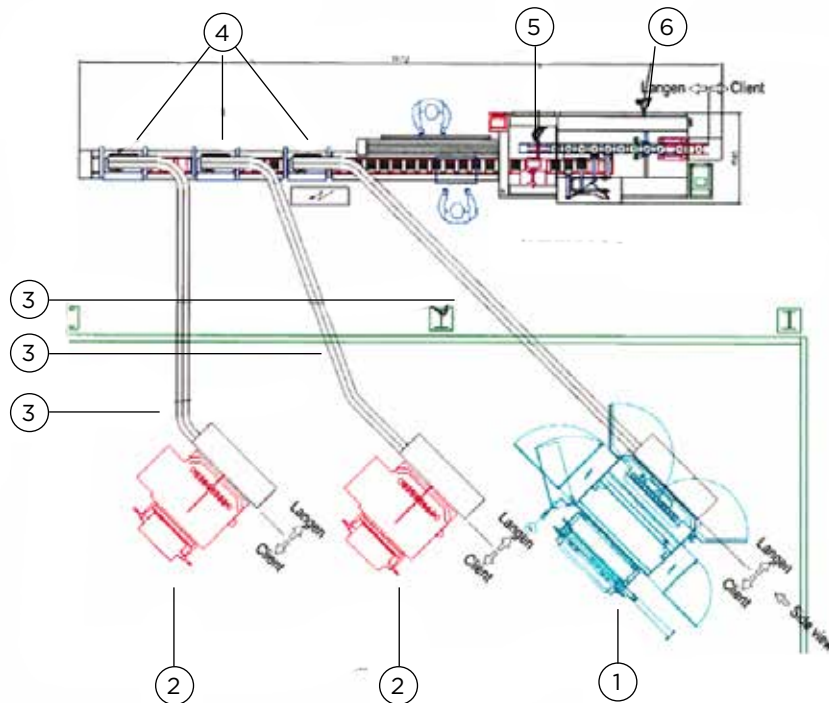

### Solution highlights

#### 1. Collation, grouping, and infeed system

- 3 multilane chutes for individual stick funnelling
- 3 droppgates as link to inclined conveyor
- 3 3-level bomb-bay systems for counting and grouping of sticks for synchronization with cartoner

#### 2. Cartoner

- 9" Langen Group VENTO™
- 2-head rotary feeder with pre break for optimal carton folding
- Overhead confiner unit
- Serrated stick pack buckets and pusher
- Food industry approved polycarbonate covers
- Monitor function for correct flap closure

1. 12 Lane stick packer
2. 8 Lane stick packer
3. Inclined conveyor
4. Infeed system for stick packs, 3-level bomb-bay system
5. Confiner unit
6. Langen Group VENTO™ (9" version)

All information given in this document is dependent upon final machine specification, infeed arrangement, product type and carton specification.

#### AMERICAS

EUROPE, MIDDLE EAST & AFRICA  
ASIA & AUSTRALIA

Canada

The Netherlands

Singapore

Thailand

Ph: +1 905 670 7200

Ph: +31 24 648 66 55

Ph: +65 62 89 37 88

Ph: +66 23 02 14 15

sales-americas@langengroup.com

sales-europe@langengroup.com

sales-asia@langengroup.com

sales-asia@langengroup.com

